

Delay-Limited Optimal Bit Loading Algorithm for OFDM Systems over Correlated Fading Channels

Md. Jahangir Hossain, Dejan V. Djonin, and Vijay K. Bhargava

Department of Electrical and Computer Engineering

University of British Columbia, Vancouver, BC, Canada

E-mail: <{jahangir,ddjonin,vijayb}@ece.ubc.ca>

Abstract—This paper explores an optimal bit loading algorithms for a multicarrier system. Specifically, we study the trade-offs between the aggregate bit error rate (BER) of an orthogonal frequency division multiplexing (OFDM) system and the buffering delay of the packets in a transmission buffer. The bit loading framework is formulated as a Markov decision process (MDP) and an optimal loading policy which minimizes the aggregate BER while meeting a target delay constraint is obtained via equivalent linear programming (LP) methodology. The complexity of finding the optimal loading policy and its' implementation issues are described briefly. Selected numerical examples show that as the number of subcarriers increases in the system, the delay-limited aggregate BER decreases.

I. INTRODUCTION

Next-generation wireless networks are expected to support a wide variety of data services. Different data applications have different traffic characteristics as well as quality of service (QoS) requirements. These QoS parameters include delay, packet error rate (PER) and bit-error-rate (BER) requirement. For example, depending on the throughput or delay requirements of the services, wireless multimedia services have already been classified as guaranteed service and best effort service [1]. In guaranteed services, the guarantee may be in the form of ensuring that the throughput is greater than some minimum value or that the delay experienced is smaller than some threshold. Through a cross-layer design approach, these inherent quality parameters of different services can facilitate efficient use of communication resources [2]. In particular, the relative delay tolerance of data applications, combined with the bursty activity patterns as well as time varying nature of the wireless channels, opens up the possibility of scheduling transmissions so as to allocate limited wireless communication resources in an efficient manner. One example of packet schedulers, in fading environments, is channel and buffer aware scheduler [3], [4], which uses cross-layer design methodology to jointly optimize the allocation of system resources.

Orthogonal frequency division multiplexing (OFDM), a form of multicarrier modulation scheme [5], is designed to meet the demands of high data rate traffic for wide band wireless communications. In an OFDM system, a high data rate system is divided into a number of parallel low data rate streams each of which is then modulated in a given narrow band frequency channel using orthogonal subcarriers. Due to its high spectral efficiency and resistance to multi-path fading channels, OFDM modulation technique is already being used in several fixed and mobile radio systems, such as asymmetric digital subscriber lines (ADSL), wireless LANs (IEEE 802.11a/g and IEEE 802.16). It has also been standardized

for digital video terrestrial (DVB-T) and audio broadcasting [6].

Assuming that the channel state information (CSI) for all subcarriers is available at the transmitter, different power or bit or both power and bit loading schemes have been proposed in literature. Different loading algorithms have different end goals (see, for example, [7] and the references therein). One broad class of bit loading algorithms minimizes the transmit power while attaining a fixed transmission rate as well as a given target BER (see, for example, [8], [9]). In another version of bit loading algorithms, ergodic capacity is maximized at a fixed transmit power. Actually, these are the two extremes of the bit loading algorithms from the perspective of delay-constrained communication over fading channels. The algorithms proposed for maximizing ergodic capacity may be suitable for services which have no delay constraint [10]. On the other hand, minimizing the total transmit power for a given rate constraint is suitable for the services which have hard delay constraint¹ [11]. An adaptive power loading algorithm which improves aggregate BER of the multicarrier system has been proposed in [12]. This scheme assigns transmission power to different subcarriers assuming the same transmission rate in each subcarrier and is again suitable for hard delay-constrained services. The other extreme of the problem i.e., minimizing the aggregate BER of the multicarrier system with no delay constraint can easily be formulated. However, if the arrived data packets can tolerate some intermediate queuing delay at the transmission buffer rather than having hard delay constraint or no delay constraint, bit loading algorithms which minimize the aggregate BER exploiting this intermediate delay constraint are interesting. Recently channel and buffer adaptive transmission techniques, which schedule packet transmission in order to meet a target delay constraint, have been proposed for single carrier case [3], [4]. Transmission rate is optimized via a cross layer optimization technique and the optimal trade-offs between different conflicting objectives are studied formulating the problem as a Markov decision process (MDP). Best to our knowledge, no research has been done to study the tradeoffs between delay-constrained communication and aggregate BER of a multicarrier transmission system. In this paper, we study and offer some novel results on adaptive bit loading for OFDM system for delay-constrained services. Specifically, we provide general MDP-based framework and optimal solution using linear programming (LP).

¹We use the term "hard delay-constraint" to mean that packets do not wait at the transmission buffer more than one time slot.

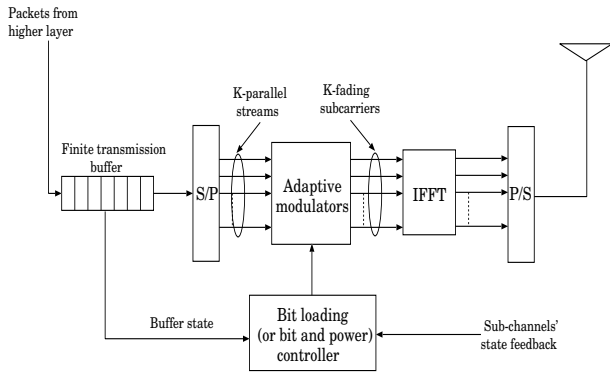

Fig. 1. Buffer and channel adaptive OFDM system.

The organization of the paper is as follows. Section II describes general OFDM bit loading and transmission framework including channel, traffic and rate adaptation model. In Section III, optimal bit loading policy is obtained formulating the transmission framework as a MDP. Computer simulation results are also presented in this Section. Finally the important remarks of our study are presented in Section V to conclude the paper.

Notation: Subscripts are reserved to denote a specific state of a state space, while superscripts are reserved to denote the subcarrier index. Subscript in brackets denotes the state at a certain transmission slot n .

II. SYSTEM MODEL

A system model for buffer and channel adaptive transmission system is shown in Fig. 1 where we assume a single class of traffic is to be transmitted over fading channels using an OFDM system with K subcarriers. It is assumed that each subcarrier undergoes frequency flat fading. Data packets, which arrive from higher layers, are stored in a finite size transmission buffer of length L in order to be transmitted later. In each transmission slot, the transmitter adaptively assigns a number of bits to different subcarriers jointly considering the state of buffer occupancy as well as different subcarriers' states. The assigned bits in each subcarrier are modulated into M-ary quadrature modulation (M-QAM) symbol which are then transmitted over multiple subcarriers.

A. Channel Models

Let the total transmit signal power be P_T [W] and the total bandwidth of the OFDM system be W_T [Hz]. We assume that total power as well as bandwidth is equally divided among K subcarriers. Therefore, the transmit power per carrier, $P = P_T/K$ [W] and bandwidth per carrier $W = W_T/K$ [Hz]². Given the channel fading amplitude at i th carrier, α^i and a noise power spectral density of N_0 [W/Hz], let us define carrier symbol to noise ratio (SNR) at the receiver for the i th carrier $\gamma^i = (\alpha^i)^2 P/N_0 W$. The SNR channel estimation

²We assume the total bandwidth are divided into K disjoint ranges. In an OFDM system, there may exist spectral overlapping between adjacent carriers. This assumption is used in numerical examples and does not affect our proposed transmission framework and choice of optimal policy.

for each subcarrier is performed at the receiver and these estimates are sent back to the transmitter assuming no delay and no error in the transmission on the feedback channel. SNR estimates on carrier i , γ^i corresponds to a discrete set $\mathcal{C}^i = \{c_1^i, \dots, c_\Gamma^i\}$ of channel states where it is assumed that there are Γ such discrete states. Let i th carrier be in the state c_j^i if γ^i is in the interval $\phi_{j-1} \leq \gamma^i \leq \phi_j$. Here it is assumed that SNR thresholds satisfy the following inequality: $0 = \phi_0 \leq \dots \leq \phi_j \leq \dots \leq \phi_\Gamma = \infty$. The channel is assumed to be block fading as it is assumed that the SNR at the receiver stays in the given interval during the duration of the whole transmission slot. The probability density function (pdf) of the SNR of i th carrier in state l , $p_l^i(\gamma)$ is considered to be known. Further, it is assumed that channel states of i th carrier form an ergodic Markov chain which is independent across the carriers. The composite channel state is defined as $c = (c^1, c^2, \dots, c^K)$, where $c^i \in \mathcal{C}^i$, defines the snapshot of carrier states in all parallel carriers. The number of composite channel states in state space $\mathcal{C} = \mathcal{C}^1 \times \mathcal{C}^2 \times \dots \times \mathcal{C}^K$ is Γ^K . If the fading conditions among the subcarriers are independent, they can be obtained by simply taking the product of individual carrier's state transition probability. For example, we assume that the channel of i th carrier can be represented by finite state Markov chain (FSMC) [13]. For Rayleigh faded channel, the probability density function (pdf) of the SNR of i th carrier, γ^i is given as

$$p_{\gamma^i}(\gamma^i) = \frac{1}{\gamma_0} \exp\left(-\frac{\gamma^i}{\gamma_0}\right) \quad (1)$$

where γ_0 is the average SNR. For a given fading rate (i.e., Doppler frequency, f_d) the transition probabilities between the channel states of the FSMC can be found, for example, in [13].

B. Incoming Traffic Model

The incoming traffic i.e., the packet arrival process at the transmission buffer is assumed to be constant \bar{F}_{sec} packets per second. If the duration of a slot is equal to T_s [Sec], the packet arrival rate is $\bar{F} = \bar{F}_{sec} T_s$ packets per slot. It is important to mention that for a given total bandwidth, the symbol duration of an OFDM system depends on the number of sub-carriers. For example, if we assume a K carrier OFDM system and ideal Nyquist signalling, the duration of a symbol is $T_{sym} = K T_{sym}^{sc}$, where $T_{sym}^{sc} = 1/W_T$ is the duration of a symbol for the equivalent single carrier system. In our transmission frameworks we assume that N_s OFDM symbols are transmitted in each transmission slot irrespective of the number of carriers in the system. Therefore, the duration of a transmission slot, T_s [Sec] is also different for different number of carriers in the system for a given total bandwidth. We also assume a packet length of N_p bits per packet. The number of packets that are transmitted in a slot depends on the total number of bits loaded in OFDM subcarriers in that given slot.

C. Rate Adaptation Model

Adaptive M-QAM modulation is performed in each carrier. The adaptive modulator in carrier i is assigned an action a^i from the set of possible actions \mathcal{A}^i . It is assumed that

the same rate actions are available in all carriers. Without loss of generality we assume that the set of available actions $\mathcal{A}^i = \{a_1, a_2, a_3 \dots a_U\}$, $\forall i$ where action a_1 and a_u ($u = 2, 3, \dots, U$) correspond to transmitting no packet and u packets using $M = 2^u$ -QAM modulation, respectively. The composite action space, \mathcal{A} is the combination of all possible transmission rates in each subcarrier and is defined as K -tuple $a = (a^1, a^2, \dots, a^K)$, where $a^i \in \mathcal{A}^i$ and $a \in \mathcal{A}$ has total of $A = U^K$ actions. The role of the rate scheduler is to choose this composite action, $a \in \mathcal{A}$ based on the current composite channel state $c \in \mathcal{C}$ and the current buffer state, $b \in \mathcal{B}$, where $\mathcal{B} = \{B_1 B_2 \dots B_L\}$ is the buffer state space. Taking an action based on the buffer as well as the composite channel state is specified by a decision rule which we call policy. More specifically, the stationary deterministic policy π , which does not depend on time index, specifies action $a_{(n)}$ at time step n as a function of the channel state $c_{(n)}$ and the buffer state $b_{(n)}$, i.e., $a_{(n)} = \pi(b_{(n)}, c_{(n)})$.

If a feasible action³ $a_{(n)} = a \in \mathcal{A}$ is taken at time step n , the buffer dynamics can be expressed as

$$b_{(n+1)} = b_{(n)} + \bar{F} - \frac{N_s}{N_p} \sum_{i=1}^K \Psi^i(a_{(n)}) \quad (2)$$

where $b_{(n+1)}$ and $b_{(n)}$ denote the buffer occupancy at time step n and $n + 1$, respectively. $\Psi^i(a)$ returns the number of bits per symbol assigned to i th carrier if composite action $a_{(n)}$ is taken. Without loss of generality, we use a normalized packet length i.e., the values of N_p and N_s in Eq. (2) are chosen such that the ratio N_s/N_p is equal to one. As a consequence we omit this ratio throughout the rest of the paper. In practice, the packet length N_p can be thousands of bits per packet and the ratio can take any integer value.

The BER of a given subcarrier is generally a function of the SNR γ as well as the number of bits v assigned to the subcarrier and can be written as

$$\text{BER}(\gamma, v) = f(\gamma, v) \quad (3)$$

where $f(\cdot, \cdot)$ is the BER function determined by specific modulation and coding scheme. When uncoded square M-QAM is used in each subcarrier, a good approximation can be expressed as [15]

$$f(\gamma, v) = 0.2 \times \exp \left[\frac{-1.6\gamma}{\sigma^2(2^v - 1)} \right] \quad (4)$$

where $\sigma^2 = WN_0$ is the equivalent noise power per carrier.

Since we use discrete channel state which is mapped to a unique range of SNRs rather than a unique instantaneous SNR value, using the expression of average BER in a given channel state is appropriate. For uncoded square QAM constellation and Rayleigh fading channel of Section II-A, the average BER of i th carrier, $\overline{\text{BER}}$ over channel state c_j^i , $j = 1, 2, \dots, \Gamma$ can be written as

$$\overline{\text{BER}}(c_j^i, v) = \frac{0.2[\exp(-k_1\phi_{j-1}) - \exp(-k_1\phi_j)]}{k_1\gamma_0 \left[\exp(-\frac{\phi_{j-1}}{\gamma_0}) - \exp(-\frac{\phi_j}{\gamma_0}) \right]} \quad (5)$$

³A feasible action does not lead to buffer overflow or negative buffer occupancy. Detailed description of feasible actions will be given in Section III-A.

where

$$k_1 = \frac{1.6}{\sigma^2(2^v - 1)} + \frac{1}{\gamma_0}. \quad (6)$$

III. SCHEDULING ALGORITHMS

A. Problem Formulation

An unconstrained MDP is a model for deciding on how to act in a stochastic environment where outcomes are uncertain [14]. It is described through a set of decision epochs or time slots or stages $\mathcal{T} = 1, 2, \dots, n$, a set of states $\mathcal{S} = \{s^1, s^2, \dots, s^N\}$, a set of actions $\mathcal{A} = \{a^1, a^2, \dots, a^U\}$, a set of state and action dependent immediate costs $x: \mathcal{K} \mapsto \mathbb{R}$, and a set of state and action dependent transition probabilities. Set $\mathcal{K} = \{(s, a) : s \in \mathcal{S}, a \in \mathcal{A}_s\}$ is the set of state-action pairs. While the system is in state $s_{(n)} = s^j \in \mathcal{S}$ at decision epoch or time-slot n , the decision maker selects an action $a_{(n)}$ from the set of actions \mathcal{A}_{s^j} available at state $s^j \in \mathcal{S}$, where $\cup_{s^j \in \mathcal{S}} \mathcal{A}_{s^j} = \mathcal{A}$. In the next time-slot, the system moves to a state $s^k \in \mathcal{S}$ according to the transition probability $p(s_{(n+1)} = s^k | s_{(n)} = s^j, a_{(n)})$ and the decision maker incurs a one step immediate cost $x(s_{(n)}, a_{(n)})$.

A policy as a mapping from state to actions specifies the decision rule to be used at all time slots or decision epochs. With a stationary deterministic policy π , the expected long-term average cost per stage is

$$J_\pi = \lim_{M \rightarrow \infty} \frac{1}{M} \sum_{n=1}^M \mathbb{E}_s[x(s_{(n)}, \pi(s_{(n)}))], \quad (7)$$

where expectation, $\mathbb{E}_s[\cdot]$ is over random evolution of the states of the MDP. An optimal policy denoted by π^* is the one that incurs the minimum average cost per stage i.e.,

$$\pi^* = \arg \min_{\pi \in \Pi} J_\pi \quad (8)$$

where Π is a set of all stationary admissible deterministic policies. In general this minimization should be performed over the set of all causal policies. However, for both our transmission frameworks, optimal policy for given MDP exists and is contained within the set of stationary deterministic policies [14].

The composite state space \mathcal{S} of adaptive bit loading framework is composed of the buffer state space \mathcal{B} and composite channel state \mathcal{C} . The number of states in $\mathcal{S} = \mathcal{C} \times \mathcal{B}$ is $N = L \times \Gamma^K$. Since a finite size buffer is used at the transmitter, taking some actions at specific buffer states lead to buffer overflow. This overflow can be avoided by taking an action $a_{(n)}$ at time slot n such that

$$b_{(n)} + \bar{F} - \sum_{i=1}^K \Psi^i(a_{(n)}) \leq L. \quad (9)$$

On the other hand, the transmitter can not transmit more packets than available at the buffer. So, the action a has to follow the following inequality:

$$\sum_{i=1}^K \Psi^i(a_{(n)}) \leq b_{(n)}. \quad (10)$$

Using Eqs. (9) and (10) a feasible action space in state s , \mathcal{A}_s , where, $\cup_{s \in \mathcal{S}} \mathcal{A}_s = \mathcal{A}$ can be found easily.

Transition probabilities between states are based on transition probabilities of channel Markov chains and buffer dynamics Eq. (2) and can be expressed as follows:

$$p(s_{(n+1)} = s^j | s_{(n)} = s^i, a_{(n)}) = P(\Lambda(s^j) | \Lambda(s^i)) \times \delta(\nabla(s^j) - (\nabla(s^i) - \sum_{i=1}^K \Psi^i(a_{(n)}) + \bar{F})) \quad (11)$$

for certain $a_{(n)} = a \in \mathcal{A}_{s^i}$, and $s^i, s^j \in \mathcal{S}$. Functions $\Lambda(s)$ and $\nabla(s)$ return the composite channel state c and the buffer state b of composite state s , respectively. $\delta(x)$ returns 1 if $x = 0$ and 0 otherwise.

In our proposed bit loading framework, we have two types of cost; delay cost and aggregate BER cost. The aggregate BER of the multicarrier system in state, $s_{(n)} = s \in \mathcal{S}$ for taking an action $a_{(n)} = a \in \mathcal{A}_{s_n}$ can be written as

$$\text{BER}_{\text{agg}}(s_{(n)}, a_{(n)}) = \frac{\sum_{i=1}^K \overline{\text{BER}}(\ell^i(s_{(n)}), \Psi^i(a_{(n)})) \Psi^i(a_{(n)})}{\sum_{i=1}^K \Psi^i(a_{(n)})}, \quad (12)$$

where ℓ^i returns i th carrier channel state of composite state s . The expected long-term average BER cost under policy π is

$$\overline{\text{BER}}_{\text{agg}}(\pi) = \lim_{M \rightarrow \infty} \frac{1}{M} \sum_{n=1}^M \mathbb{E}_s[\text{BER}_{\text{agg}}(s_{(n)}, \pi(s_{(n)}))]. \quad (13)$$

The delay cost is the average number of time slots that a packet has to wait at the transmission buffer before transmission. The immediate delay cost due to buffer occupancy under the policy π

$$d(s_{(n)}, \pi(s_{(n)})) = \frac{\nabla(s_{(n)})}{\bar{F}}. \quad (14)$$

According to Little's formula, the time average delay in the buffer, \bar{D} can be expressed as

$$\bar{D}(\pi) = \lim_{M \rightarrow \infty} \frac{1}{M} \sum_{n=1}^M \mathbb{E}_s[\frac{b_{(n)}}{\bar{F}}]. \quad (15)$$

Since both the costs; BER and delay costs are conflicting with each other, we can formulate the problem as an unconstrained Markov decision process (UMDP) with a trade-off factor or a constrained Markov decision process (CMDP). When the problem is posed as an UMDP, the immediate cost function under a stationary deterministic policy π is

$$x(s_{(n)}, \pi(s_{(n)})) = \frac{\nabla(s_{(n)})}{\bar{F}} + \beta \text{BER}_{\text{agg}}(s_{(n)}, \pi(s_{(n)})) \quad (16)$$

where $\beta (> 0)$ is a trade-off factor and by changing its value we can obtain different trade-offs between average delay and aggregate BER. For a given β , the stationary deterministic optimal policy π^* can be obtained using dynamic programming such as relative value iteration (RVI) or policy iteration (PI) [14]. Minimum aggregate BER and average delay under the policy π^* are obtained from Eqs. (13) and (15).

In CMDP, the objective cost is minimized while keeping the other costs (called constrained costs) below some given bounds. In this proposed framework, our objective is to minimize the aggregate BER while keeping delay cost below

a target thresholds, the problem thus can be formulated as follows

$$\arg \min_{\pi \in \Pi_R} \overline{\text{BER}}_{\text{agg}}(\pi) \quad (17)$$

$$\text{subject to: } \bar{D}(\pi) \leq D_t \quad (18)$$

where Π_R is the set of all randomized stationary policies that are uniquely characterized with probabilities $\theta_{(s)}^\pi(a)$ of applying action $a \in \mathcal{A}_s$ in state $s \in \mathcal{S}$. D_t is an allowable maximum long-term average delay. The formulated CMDP can be solved using equivalent LP methodology [14]. A brief description on equivalent LP methodology to find optimal bit loading policies is given in the next Section.

B. Optimal Scheduling

Although dynamic programming offers an elegant, unified treatment of a wide range of stochastic control problems, the curse of dimensionality gives rise to prohibitive computational requirements of large-scale problems, such as this OFDM bit loading problem. There are number of algorithms, for example, RVI, PI, and LP that can be used to find the optimal solution for stochastic optimization problems formulated as a MDP. LP is studied in solving MDP models because of it's elegant theory and the ease in which it allows inclusion of constraints [14]. To describe the dual LP let us consider $z(s, a)$ represents the "steady-state" probability that the process is in state s and action a is applied. We seek to find the control policy which is represented in terms of probability distribution z over $\mathcal{S} \times \mathcal{A}$. The optimal policy z^* can be obtained as

$$\text{minimize } \sum_{s \in \mathcal{S}, a \in \mathcal{A}_s} \text{BER}_{\text{agg}}(s, a) z(s, a) \quad (19)$$

subject to :

$$\sum_{s \in \mathcal{S}, a \in \mathcal{A}_s} d(s, a) z(s, a) \leq D_t \quad (20)$$

$$\sum_{a \in \mathcal{A}_j} z(j, a) = \sum_{s \in \mathcal{S}, a \in \mathcal{A}_s} z(s, a) p(j|s, a), \forall j \in \mathcal{S} \quad (21)$$

$$\sum_{s \in \mathcal{S}, a \in \mathcal{A}_s} z(s, a) = 1 \quad (22)$$

$$z(s, a) \geq 0, \forall s \in \mathcal{S}, \forall a \in \mathcal{A}_s. \quad (23)$$

The inequality constraint in Eq. (21) is to keep the long-term average delay below the given threshold whereas the equality constraint in Eq. (22) satisfies the well known Chapman-Kolmogorov equation. The constraint in Eq. (23) ensures that the sum of the probabilities $z(s, a)$ is equal to one while Eq. (24) is ensuring that the individual probability is greater than zero.

If there exist an optimal solution z^* to the LP, there exists a stationary policy π^* that is optimal for the CMDP. Now

$$\theta_{\pi^*(s)}(a) = \frac{z^*(s, a)}{\sum_{a' \in \mathcal{A}_s} z^*(s, a')} \quad \text{if } \sum_{a' \in \mathcal{A}_s} z^*(s, a') > 0. \quad (24)$$

If $\sum_{a' \in \mathcal{A}_s} z^*(s, a') = 0$ for some $s \in \mathcal{S}$, an action that drives the system to $\mathcal{S}_{z^*} = \{s \in \mathcal{S} : \sum_{a' \in \mathcal{A}_s} z^*(s, a') > 0\}$ is chosen in each state [14].

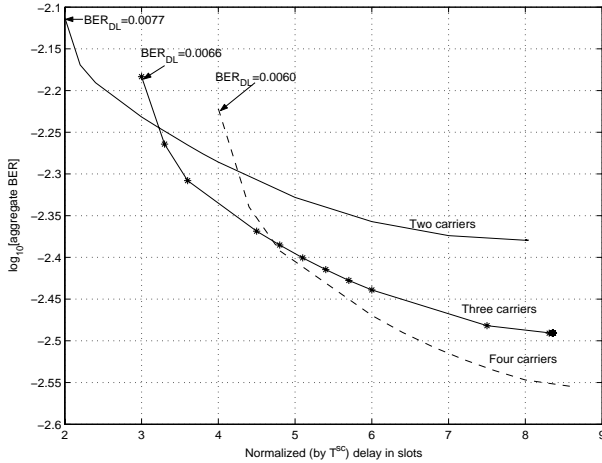

Fig. 2. Optimal Delay and aggregate BER trade-offs with different number of carriers (Doppler frequency, $f_d = 300\text{Hz}$).

The delay-BER trade-offs for different number of carriers are shown in Fig. 2. In order to make a fair comparison, we used the same total transmit power, $P_T = 1\text{mW}$, total system bandwidth of $W_T\text{[Hz]}$, and noise spectral density, $N_0 = 1\text{mW/Hz}$. We used three state Rayleigh channel model for each carrier. The states are partitioned such that probabilities of being in each state are equal. For example, this type of channel model can be found in [3], [4]. The channel variations across the subcarriers are assumed to be identically and independently distributed (i.i.d) with an average received power gain, $\gamma_0 = 15\text{dB}$. The available rate set per carrier, $\mathcal{A}^i = [0 \ 2 \ 4]$. A packet arrival rate of 2 packets/ time slot for equivalent single carrier case is used and thus the packet arrival rate for k carrier system is $2 \times k$ packets per time slot. As mentioned in Section II-B that the slot duration of a MC system with k number of subcarriers is $T^k = k \times T_s^{sc}$, where T_s^{sc} is the slot duration of an equivalent single carrier system. Therefore, in Fig. 2, the average delay for different number of carriers is normalized by the duration T_s^{sc} . In our proposed framework, the minimum achievable delay is, therefore, k times that of an equivalent single carrier system and consequently the minimum achievable delay starts from k time slots rather than starting from one time slot. This figure also shows that as the maximum tolerable delay increases the aggregate BER decreases. This is expected because of temporal diversity (TD) effects. The packet can wait until at the transmission buffer until channel condition is good enough to be transmitted. If there is no delay constraint, the minimum achievable aggregate BER, which corresponds to water filling case, can be achieved. It is interesting to see that as the number of carriers increases in the system, the delay limited aggregate BER, in high delay tolerant region, decreases for the same traffic arrival rate (packets per second). This is owing to the spectral diversity (SD) effects. As there are more carriers in the system, more SD is achieved. It is also interesting to observe that in some delay-constrained regions, especially in low delay-constrained region, although the system has higher number of

carriers, the aggregate BER is higher (see cross-over between the curves in Fig. 2). This is due to the fact that in that region, the TD takes over the SD. In other words, the TD is more dominant than SD.

IV. CONCLUSIONS

In this paper, we have proposed an optimal bit loading algorithm of an OFDM system for delay-constrained communication over correlated fading channels. Specifically, we have explored the optimal trade-offs between the aggregate BER of an OFDM system and the buffering delay of the packets at the transmission buffer. The selected numerical results show that the delay limited aggregate BER, in higher delay tolerant regions, decreases as the number of carriers increases in the system. Finding the optimal policies and implementing them in reality is highly complex due to memory space limitation. Therefore, we are currently investigating simple suboptimal loading schemes. We are also investigating the optimal power loading algorithms of multicarrier systems for delay-constrained communication over correlated fading channels.

REFERENCES

- [1] S. Shakkottai, T. S. Rappaport, and P. C. Karlsson, "Cross-layer Design for Wireless Networks," *submitted for possible Journal publication*, June 2003. Also available in <http://www.ece.utexas.edu/shakkott/Pubs/cross-layer.pdf>.
- [2] R. Berry and R. Gallager, "Communication over fading channels with delay constraints," *IEEE Trans. Inform. Theory*, vol. 48, pp.1135-1149, May 2002.
- [3] A. T. Hoang and M. Motani, "Buffer and channel adaptive modulation for transmission over fading channels," in *Proc. IEEE Int. Conf. Commun. (ICC'03)*, Anchorage, AK, vol. 4, May 2003, pp. 2748-2752.
- [4] D. Djonin, A. K. Karmokar, and V. K. Bhargava, "Optimal and sub-optimal packet scheduling over correlated fading channels," in *Int. Conf. Commun.*, June 2004, Paris, France, pp. 906-910.
- [5] J. A. C. Bingham, "Multicarrier modulation for data transmission: an idea whose time has come," *IEEE Commun. Mag.*, vol. 28 pp. 5-14, May 1990.
- [6] *DVB-T Standard: ETS 300 744, Digital Broadcasting Systems for Television, Sound and Data Services: Framing Structure, Channel Coding and Modulation for Digital Terrestrial Television*, ETSI Draft EN300 744, 1999-1, 1999.
- [7] A. T. Toyserkani, J. Ayan, S. Naik, Y. Made, and O. Al-Askary, "Sub-carrier based adaptive modulation in HIPERLAN/2 system," in *IEEE Int. Conf. Commun.*, Paris, France, June 2004 pp. 3460-3464.
- [8] L. Goldfeld and V. Lyandres, "Capacity of the multicarrier channel with frequency-selective Nakagami fading," *IEICE Trans. Commun.*, vol. E83-B, no. 3, pp. 697-702, March 2000.
- [9] C. Y. Wong, R. S. Cheng, K. B. Letaief, and R. D. Murch, "Multiuser OFDM with adaptive subcarrier, bit, power, and power allocation," *IEEE J. Select. Areas Commun.*, vol. 17, no. 10, pp. 1747-1758, October 1999.
- [10] D. N. C. Tse and S. V. Hanly, "Multiple access fading channels - part I: polymatroid structure, optimal resource allocation and throughput capacities," *IEEE Trans. Inform. Theory*, vol. 44 no. 7, pp. 2796-2815, November 1998.
- [11] S. V. Hanly and D. N. C. "Multiaccess fading channels. II. Delay-limited capacities", *IEEE Trans. Inform. Theory*, vol. 44 no. 7, pp. 2816-2831, May 1998.
- [12] C. S. Park and K. B. Lee, "Transmit power allocation for BER performance improvement in multicarrier systems," *IEEE Trans. Commun.*, Vol. 52 No. 10, pp. 1658-1663, October 2004.
- [13] H. S. Wang and N. Moayeri, "Finite-state Markov channel-A useful model for radio communication channels," *IEEE Trans. Veh. Technol.*, vol.44, pp. 163-171, Feb. 1995.
- [14] M. L. Putterman, "Markov decision processes : discrete stochastic dynamic programming," New York : John Wiley & Sons, 1994.
- [15] A. J. Goldsmith and S-G. Chua, "Variable-rate variable-power MQAM for fading channels," *IEEE Trans. Commun.* vol. 45, pp. 1218-1230, Oct. 1997. pp. 1603-1607.