

# *Compressive sensing analog-to-information system based on optical speckle*

T. J. Shaw, G. C. Valley, G. A. Seffler and A. C. Scofield  
 Photonics Technology Department  
 The Aerospace Corporation  
 Los Angeles, CA 90009-2957  
 george.valley@aero.org

**Abstract**— Speckle in multimode optical waveguides provides random projections needed for a photonic compressive sensing GHz-band analog-to-information system. RF signals modulate chirped optical pulses that propagate through a 5-m long, 105- $\mu\text{m}$  multimode fiber resulting in an output speckle pattern that depends on both the optical and RF signals. We make 16 parallel measurements at 35.7 MSA/s per channel and recover amplitude, phase and frequency for 1 or 2 tones in the 2-19 GHz band with 4.5-ns time windows. We also present results from a speckle-based RF spectrometer using a single-frequency laser, 10-cm long, 100- $\mu\text{m}$  wide planar waveguide and camera.

**Keywords**—optical signal processing, microwave photonics, compressive sensing

## I. INTRODUCTION

Analog-to-information compressive sensing (CS) systems have been proposed and demonstrated for sparse RF signals since the first work on CS [1]. All-electronic realizations of these systems are degraded by the noise in the electronic methods used to perform the random projections for CS, and the size, weight and power consumption needed for the electronics are incompatible with many applications. These considerations motivated us to investigate photonic realizations [2,3] and our recent work uses laser speckle to perform the CS random projections [4,5]. Here we present new work on recovering RF signals modulated on optical fields that have passed through multimode waveguides. We present results from two systems: In the first system, the RF is modulated on a chirped optical field such that the time dependence of the RF is encoded on the wavelength of the optical field (time-wavelength mapping) and then the optical field propagates through a multimode fiber such that the wavelength dependence of the speckle in the fiber provides pseudo-random projections of the RF while the spatial dependence of the speckle at the output of the fiber provides independent measurements of the random projections. In the second system, the RF is modulated on a stable single-frequency laser diode and then the optical field propagates through a multimode planar waveguide. In this case the modulator is biased such that the optical field out of the modulator has components at frequencies equal to the laser frequency plus and minus the radio frequency. In this

spectroscopic system, the RF can be recovered using a dictionary of speckle patterns as a function of frequency [6].

## II. EXPERIMENTAL SET UP: SPECKLE-BASED CS

Fig. 1 shows the experimental set up for the CS system that uses a chirped optical field, time-wavelength mapping and a multimode fiber. A mode-locked laser (MLL) provides short broadband pulses ( $\sim 25$  nm bandwidth), dispersion compensating fiber stretches these pulses to 4.5 ns as shown in the inset, and a Mach-Zehnder modulator (MZM) impresses the RF waveform (derived from an arbitrary waveform generator AWG) on the optical field. Next the optical field is split with one half going to a photodiode and high-speed oscilloscope for diagnostics, such as the inset waveform, and the other half propagating through an erbium-doped fiber amplifier (EDFA) and into the a 5-m long, 105-micron diameter multimode fiber (MMF). The output of the MMF is imaged onto a 32-fiber bundle chosen such that the diameter of the fibers in the bundle approximately matches the size of the speckle lobes in the image of the fiber. Each of the 32 fibers terminates in a photodiode (PD) and the currents from pairs of PDs are subtracted (differential detection) before being digitized by 16 channels of 4 separate oscilloscopes.

## III. CALIBRATION OF THE CS SYSTEM

Recovering sparse RF signals from a CS system such as shown in Fig. 1 requires accurate knowledge of the random projections or equivalently of the CS measurement matrix. In earlier work [4] we measured the wavelength and spatial dependence of the speckle directly using a highly stable tunable laser and imaging the output of the fiber onto a camera. This procedure has two issues: first the RF signal itself changes the speckle pattern in addition to the time-wavelength mapping, and second temperature fluctuations in our laboratory cause long-term (minutes) drifts in the speckle pattern for the multimode fiber which is not packaged or thermally controlled. For these reasons, we decided to measure a calibration dictionary of the speckle response to RF signals from  $f_{\text{MIN}}$  to  $f_{\text{MAX}}$  with a grid spacing  $\Delta f$  for multiple laser pulses. From the calibration dictionary, we derive the CS measurement matrix via singular value decomposition [7] After the calibration signals have been measured, a series of

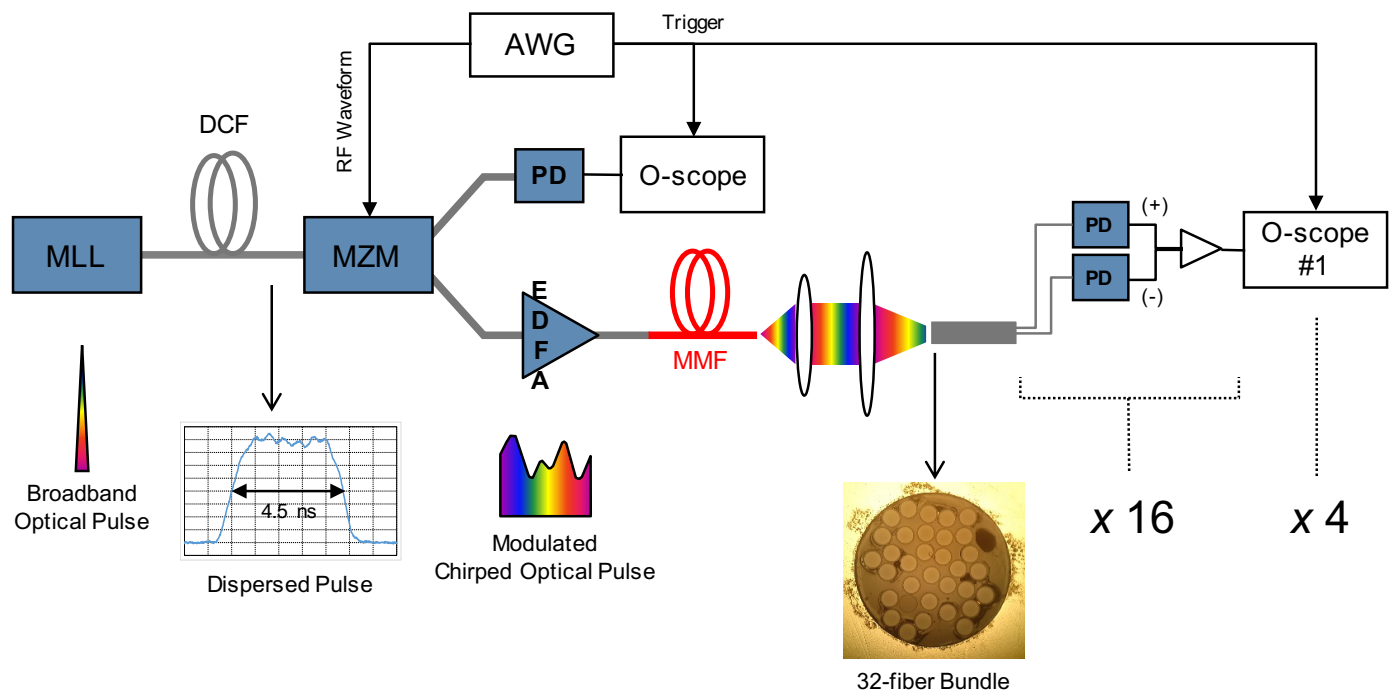

Fig. 1. Experimental setup (MLL: Mode-locked laser; MZM: Mach-Zehnder modulator; PD: Photodiode; EDFA: Erbium-doped fiber amplifier; MMF: Multimode fiber; AWG: Arbitrary waveform generator).

test signals are measured. In results presented here we recover the RF signals using conventional penalized  $\ell_1$  norm codes [8]. Both the calibration and the test signals are taken within a 0.4-ms time window, which is much shorter than any temperature variations in our laboratory.

#### IV. RESULTS FOR TIME-WAVELENGTH CS SYSTEM

First, we programmed the AWG to step from 8.77 to 10.73 GHz ( $\Delta f = 35$  MHz) to obtain the calibration dictionary and then used the measurement matrix obtained from this dictionary to determine the amplitude, phase and frequency of two tones. Fig. 2 shows recovered amplitude as a function of frequency; each individual curve represents the measurement in a single 4.5 ns pulse. Note that two tones are clearly resolved but single measurements are not especially accurate (the black arrows denote the input frequencies).

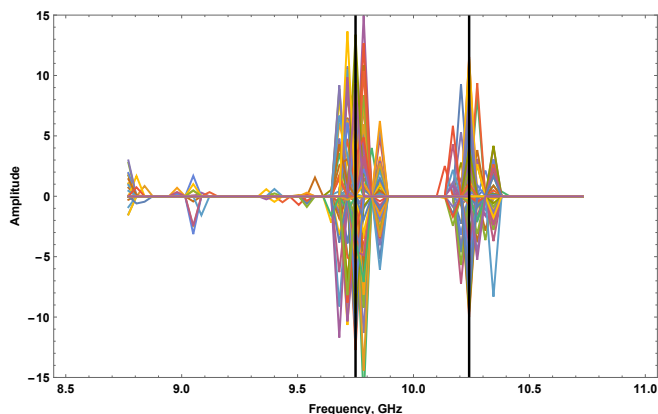

Fig. 2. Amplitude as a function of frequency for 2-tone test. The black lines indicate the frequency of the input tones.

In a second experiment, we programmed the AWG to step from 17.45 to 18.55 GHz ( $\Delta f = 25$  MHz) and 17.976 to 18.024 GHz ( $\Delta f = 1$  MHz) with the results shown in Fig. 3. Note that we resolve frequency to about 25 MHz in a single pulse but cannot resolve 1 MHz. Multiple pulses can be used to resolve frequencies to much better than 1 MHz [5].

In a third experiment, we programmed the AWG to step from 2 to 19 GHz ( $\Delta f = 50$  MHz) and calculated the phase of the RF signal relative to the laser pulse. Fig. 4 shows the recovered phase as a function of pulse number and frequency. Note that for each frequency there are 25 dots corresponding to 25

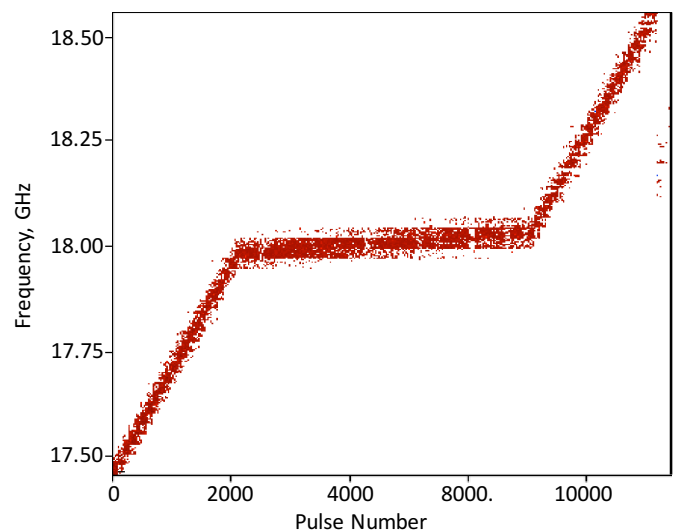

Fig. 3. Recovered frequency as a function of pulse number with frequency scanned from 17.45 to 18.55 GHz.

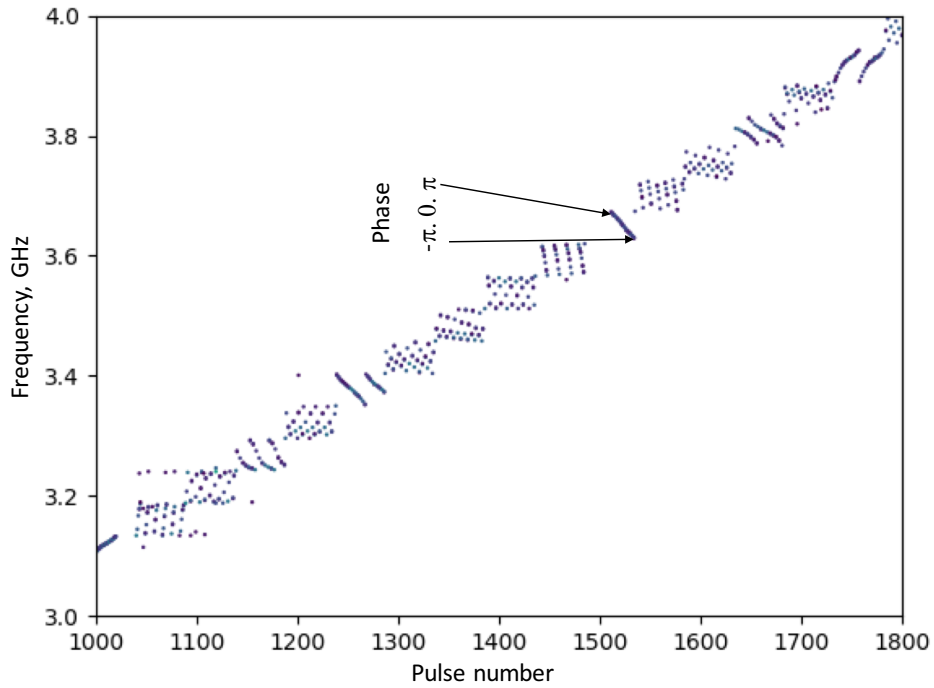

Fig. 4. Phase as a function of pulse number for frequency from 3 to 4 GHz ( $\Delta f = 50$  MHz).

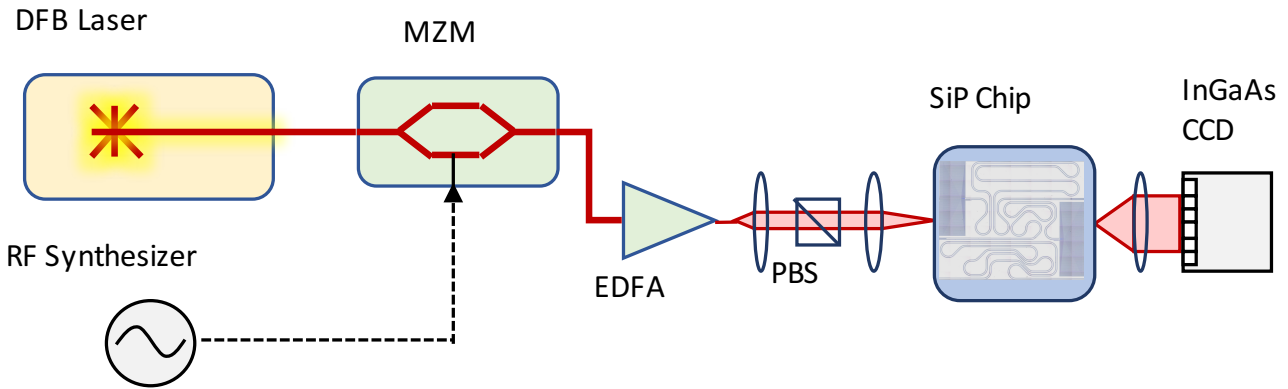

Fig. 5. Spectroscopic system for measuring radio frequency using speckle in a planar waveguide.

measurements at that frequency. The differing patterns can be understood by the relationship between the RF and the laser pulse repetition rate. For example, if the RF were an integral multiple of the laser pulse repetition rate, then the phase would be constant (horizontal row of dots).

### V. SPECTROSCOPIC SYSTEM

A schematic diagram of the spectroscopic system is shown in Fig. 5. The optical field from a distributed feedback (DFB) laser propagates through an MZM where it is modulated by the RF signal from a synthesizer, propagates through an EDFA and a polarizing beam splitter (PBS) and enters a 10-

cm long, 100- $\mu\text{m}$  wide planar waveguide fabricated on a silicon photonics (SiP) chip. The output of the planar waveguide is imaged onto an InGaAs charged coupled device (CCD) camera. The speckle pattern as a function of frequency and distance across the output of the waveguide, shown in Fig. 6, serves as a dictionary. The correlation of the speckle pattern at 5 GHz is computed for the speckle patterns from 0 to 10 GHz is shown in Fig. 7. With good signal-to-noise ratio it is possible to resolve RF to better than 200 MHz. Next, we modulated the optical field with two tones, one set at 3 GHz and the other scanned from 1.0 to 6.0 GHz and used the dictionary to recover the frequencies as shown in Fig. 8.

## VI. CONCLUSIONS

We present results from two systems for measuring the properties of RF signals. In the compressive sensing system, we use time-wavelength mapping and laser speckle in a multimode fiber to perform the random projections, and we recover amplitude, phase and frequency of up to 2 RF signals (6 parameters total) in the GHz band with 16 ADCs each operating at an effective rate of 35.7 MSa/s. In the spectroscopic system, we recover the frequencies of 2-tone signals with about 100-MHz resolution using a planar waveguide. The next step is substituting the planar waveguide for the multimode fiber in the CS time-wavelength system.

## ACKNOWLEDGEMENT

This work was supported under The Aerospace Corporation's Independent Research and Development Program.

## REFERENCES

- [1] J. N. Laska, S. Kirolos, M. F. Duarte, T. S. Ragheb, R. G. Baraniuk, and Y. Massoud, "Theory and implementation of an analog-to-information converter using random demodulation," *Proc. IEEE ISCAS*, 1959 (2007).
- [2] G. C. Valley and G. A. Sefler, "Optical time-domain mixer," *Proc. SPIE* **7797**, 14 (2010).
- [3] G. C. Valley, G. A. Sefler, and T. J. Shaw, "Compressive sensing of sparse RF signals using optical mixing," *Opt. Lett.* **37**, 4675 (2012).
- [4] G. C. Valley, G. A. Sefler, and T. J. Shaw, "Multimode waveguide speckle patterns for compressive sensing," *Opt. Lett.* **41**, 2529 (2016).
- [5] G. A. Sefler, T. J. Shaw, and G. C. Valley, "Demonstration of speckle-based compressive sensing system for recovering RF signals", unpublished (2018).
- [6] M. Piels and D. Zibar, "Compact silicon multimode waveguide spectrometer with enhanced bandwidth," *Scientific Reports* **7**, 1 (2017).
- [7] M. Yang, F. de Hoog, Y. Fan and W. Hu, "Adaptive sampling by dictionary learning for hyperspectral imaging," *IEEE J. Sel. Topics in Appl. Earth Obs. and Remote Sensing*, **9**, 4501 (2016).
- [8] I. Loris, "l1Packv2: A Mathematica package for minimizing an  $\ell_1$ -normalized functional." *Comput. Phys. Commun.* **179**, 895 (2008).

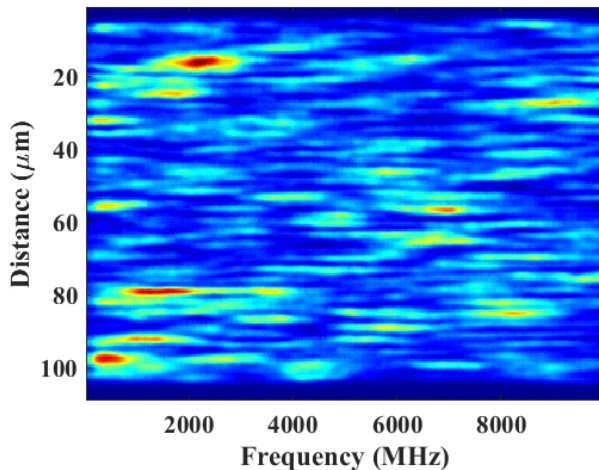

Fig. 6. Speckle pattern as a function of frequency and distance across the output of 10-cm long, 100- $\mu\text{m}$  wide planar waveguide.

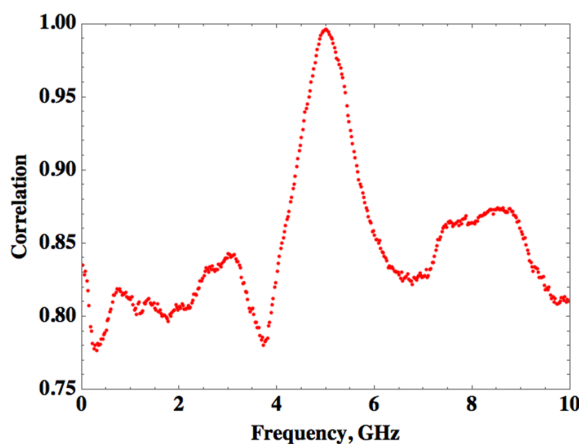

Fig. 7. Correlation of speckle pattern of 5-GHz signal with speckle patterns for frequencies from 0 to 10 GHz.

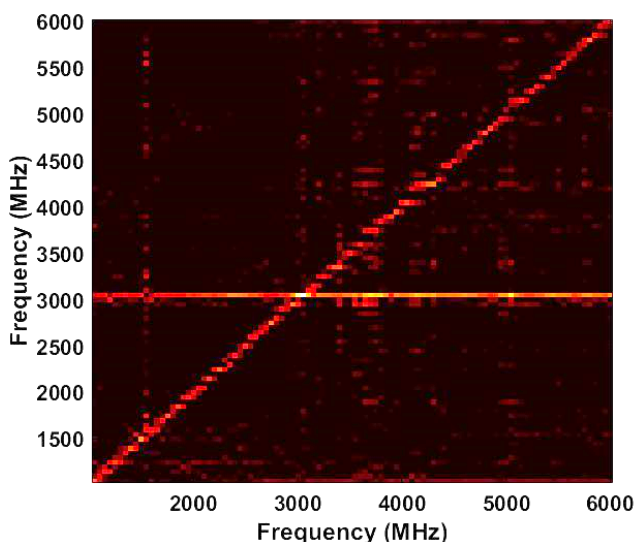

Fig. 8. Recovered frequencies (vertical) as a function of input frequency of the swept tone (horizontal).