

MULTI-CHANNEL ANC SYSTEM USING OPTIMIZED REFERENCE MICROPHONES BASED ON TIME DIFFERENCE OF ARRIVAL

Satoru Hase*, Yoshinobu Kajikawa*, Lichuan Liu†, Sen M. Kuo†

* Kansai University, Faculty of Engineering Science
3–3–35 Yamate-cho, Suita-shi, Osaka 564–8680, Japan
k222388@kansai-u.ac.jp, kaji@kansai-u.ac.jp

ABSTRACT

Feedforward active noise control (ANC) system using upstream reference signal can reduce various noises such as broadband noise by arranging a reference microphone close to a noise source. However, the performance of ANC system deteriorates if the noise environment such as the arrival direction is changed. This is because of the causality constraint that the unwanted noise propagates to the control point faster than the “antinoise” to cancel the unwanted noise. To solve this problem, we propose an ANC system that estimates the arrival direction of noise using multiple reference microphones placed around the control point. This system uses a time difference of arrival technique to estimate noise source location and then optimize reference signal. Noise reduction performances are examined through some simulations in this paper.

Index Terms— Multi-channel ANC system, feedforward control, time difference of arrival, causality constraint

1. INTRODUCTION

Feedforward active noise control (ANC) system [1–4] has a potential that reduces unwanted acoustic noise such as the broadband noise by placing the reference microphone close to the noise source [5]. The feedforward ANC system generates “antinoise” and radiates it from the secondary source to the control point to cancel out the unwanted acoustic noise. However, the feedforward ANC system may not reduce unwanted acoustic noise in some cases due to the “causality constraint” [6,7]. The “causality constraint” means that unwanted acoustic noise propagates to the control point faster than the “antinoise”. This problem occurs in the case the reference microphone is not enough close to the noise source, especially, noise reduction performance deteriorates if the direction of arrival of noise changes due to the movement. To solve this problem, we propose an ANC system that estimates the arrival direction of noise. This system estimates time difference of arrival (TDOA) between the unwanted acoustic noise at

This paper is supported by JSPS KAKENHI (15K00256).

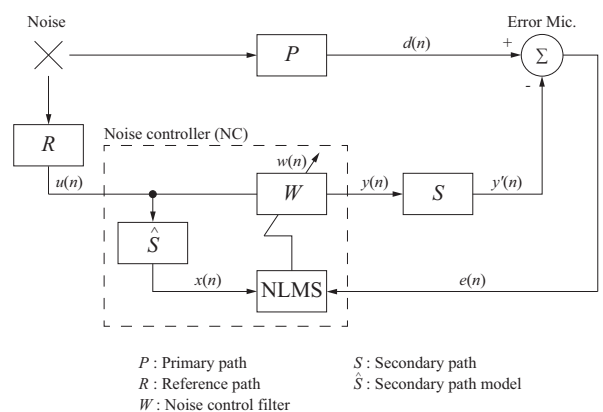

Fig. 1. Block diagram of a single-channel feedforward ANC system

the control point and the unwanted acoustic noise at the reference microphones located around the control point. Based on the TDOA, appropriate reference microphones are selected to satisfy the causality condition.

2. CAUSALITY CONSTRAINT IN FEEDFORWARD ANC SYSTEMS

In this section, we explain the causality problem of feedforward ANC systems. The block diagram of a single-channel feedforward ANC system is shown in Fig. 1. The reference signal $u(n)$ is obtained at the reference microphone, and the “antinoise” is then generated by filtering the reference signal by the noise control filter. The “antinoise” is radiated from the secondary source to the control point (error microphone position). In addition, the noise control filter is updated by the filtered-x normalized least mean square (FXNLMS) algorithm given by

$$\mathbf{w}(n+1) = \mathbf{w}(n) + \frac{\alpha}{\beta + \|\mathbf{x}(n)\|^2} \mathbf{x}(n) e(n), \quad (1)$$

where α is the step-size parameter, β is the regularization parameter, $\mathbf{x}(n)$ is the filtered reference vector, and $e(n)$ is the

error signal obtained at the error microphone, respectively.

The total delay of the reference path, noise controller, and the secondary path should be shorter than the delay of the primary path. If this condition is not satisfied, the causality constraint is violated, then the ANC performance dramatically deteriorates. In order to satisfy the causality constraint, it is therefore necessary to satisfy the following inequality:

$$D_P > D_R + D_C + D_S, \quad (2)$$

where D_P is the delay of the primary path, D_R is the delay of the reference path, D_C is the delay of computation to generate “antinoise”, and D_S is the delay of the secondary path, respectively.

3. MULTI-CHANNEL ANC SYSTEM USING OPTIMIZED REFERENCE MICROPHONES BASED ON TDOA

We propose a multi-channel ANC system using optimized reference microphones based on TDOA in this section. The overview of the proposed system and the way to select the reference microphone using TDOA are explained.

3.1. Overview of the proposed ANC system

Block diagram of the proposed ANC system is shown in Fig. 2. The block NC in Fig. 2 represents the noise controller in Fig. 1. This system includes one error microphone, one secondary source, and J reference microphones located around the control point. In addition, the noise controllers are controlled based on TDOA between reference signals and noise signal at the error microphone.

Multi-channel feedforward ANC system with J reference microphones contains J noise control filters corresponding to each reference microphone. Each noise control filter is updated by each reference signal and the error signal as

$$\mathbf{w}_j(n+1) = \mathbf{w}_j(n) + \frac{\alpha}{\beta + \sum_{p=1}^J \|\mathbf{x}_p(n)\|^2} \mathbf{x}_j(n) e(n), \quad (3)$$

where α is the step-size parameter, β is the regularization parameter, $\mathbf{x}_j(n)$ is the j -th filtered reference vector obtained at the j -th reference microphone, and $e(n)$ is the error signal obtained at the error microphone, respectively. Moreover, the “antinoise” signal is generated as the summation of outputs of each noise control filter as

$$y(n) = \sum_{j=1}^J \mathbf{w}_j^T(n) \mathbf{u}_j(n), \quad (4)$$

where $\mathbf{u}_j(n)$ is the j -th reference vector obtained at the j -th reference microphone. Generally, the multi-channel feedforward ANC system uses all reference microphones to generate “antinoise” signal. However, the reference signals that does

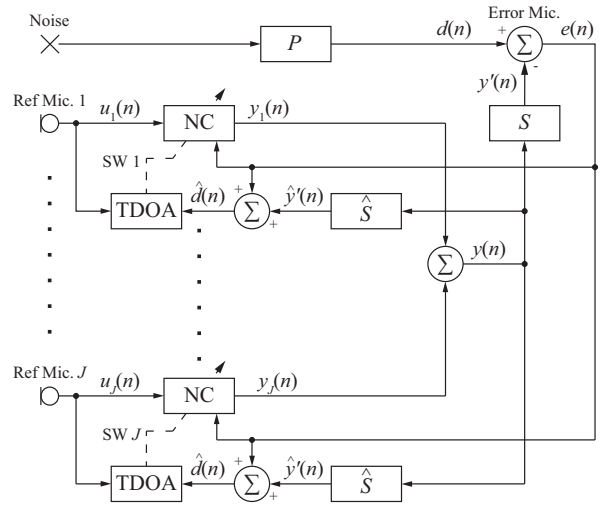

NC : Noise controller shown in Fig. 1

Fig. 2. Block diagram of multi-channel ANC system using automatically-selected reference microphones based on TDOA

not satisfy the causality constraint may cause the ANC system to degradation of noise reduction performance.

Therefore, the proposed ANC system utilizes only the reference microphones that satisfy the causality condition. Concretely, the reference signals that satisfy the causality condition are selected based on TDOA between the reference signals and the noise signal picked up at the error microphone. After that, the “antinoise” signal is generated using only the selected reference signals as

$$y(n) = \sum_k \mathbf{w}_k^T(n) \mathbf{u}_k(n), \quad (5)$$

where k is the index of microphone that satisfy the causality condition. Moreover, only the corresponding noise control filters are updated by

$$\mathbf{w}_k(n+1) = \mathbf{w}_k(n) + \frac{\alpha}{\beta + \sum_p \|\mathbf{x}_p(n)\|^2} \mathbf{x}_k(n) e(n). \quad (6)$$

In this case, the selected reference microphones must be close to the noise source. In addition, the proposed ANC system can track the changes of the noise environment based on the periodically measured TDOA, so that the ANC system can prevent the degradation of noise control performance. Moreover, the computational cost can be also saved in the proposed ANC system because several noise control filters are suspended.

3.2. Selection of the appropriate reference microphones using TDOA

Arrival direction of the noise is estimated by TDOA between each unwanted acoustic noise picked up at the error microphone and the reference microphone. TDOA is calculated from the cross-correlation of the noise signals of each microphone. Cross-correlation function is defined by

$$C_{xy}(\tau) = \sum_n x(n + \tau)y(n), \quad (7)$$

where $x(n)$ and $y(n)$ are signals, n is sample time, and τ is the time lag. The time lag giving the maximum cross-correlation means TDOA between the signals as

$$\text{TDOA}(x, y) = \arg \max_{\tau} C_{xy}(\tau). \quad (8)$$

Note that this method may not be able to be estimated in the diffuse field. Based on (8), (2) can be rewritten as

$$\text{TDOA}(u_j, d) > D_C + D_S, \quad (9)$$

where $u_j(n)$ is the reference signal obtained at the j -th reference microphone and $d(n)$ is the noise signal at the error microphone. Hence, the reference microphones to satisfy (9) can be selected in the proposed ANC system. In this case, the selected reference microphones satisfy the causality condition.

However, the error microphone can obtain only error signal between the unwanted acoustic noise and ‘‘antinoise’’. Therefore, the noise signal at the error microphone have to be estimated. The error signal is given by

$$e(n) = d(n) - \mathbf{s}^T \mathbf{y}(n), \quad (10)$$

where \mathbf{s} is the secondary path coefficient vector, and $\mathbf{y}(n)$ is the output of the noise control filter, that is, $\mathbf{s}^T \mathbf{y}(n)$ represents the ‘‘antinoise’’. Using this equation, the noise signal at the error microphone can be estimated as

$$\hat{d}(n) = e(n) + \hat{\mathbf{s}}^T \mathbf{y}(n), \quad (11)$$

where $\hat{\mathbf{s}}$ is the secondary path model coefficient vector. TDOA can be accurately estimated using this estimated noise signal $\hat{d}(n)$.

4. SIMULATION RESULTS

In this section, we demonstrate the effectiveness of the proposed ANC system using computer simulation. In the simulation, the accuracy of the selection and the noise reduction performance of the proposed ANC system are examined. Figure 3 shows the arrangement of noise sources, reference microphones, and an error microphone in the simulation. In Fig. 3, the coordinate origin is the center of the observer (HATS:

Table 1. Simulation conditions

Noise source	White noise
Sampling frequency	48000 Hz
Tap length of noise control filter W	2400
Tap length of primary path P	2400
Tap length of reference path R	2400
Tap length of secondary path S	192
Tap length of secondary path model \hat{S}	192
Step size parameter α	0.05
Regularization parameter β	1.0×10^{-6}

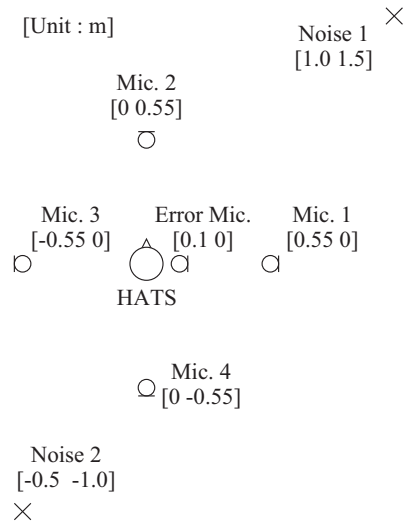

Fig. 3. Arrangement of noise sources, reference microphones, and an error microphone in the simulation

Head-And-Torso Simulator) and the error microphone is located close to the right ear of HATS. Table 1 shows the simulation conditions. Acoustic path such as reference path, primary path, and secondary path were measured in soundproof room. Figure 4 shows examples of these impulse responses. Moreover, the secondary path model is the same as the secondary path, that is, the secondary path model has no modeling error in the simulations.

Noise reduction performance is evaluated by the ‘‘Reduction’’ defined by

$$\text{Reduction} = 10 \log_{10} \frac{\sum d^2(n)}{\sum e^2(n)}. \quad (12)$$

4.1. Effectiveness of the feedforward ANC system using only reference microphones to satisfy the causality condition

In this section, we show the effectiveness of the proposed ANC system, which uses only the selected reference micro-

phones (the causality is satisfied), through comparing with an ANC system that uses arbitrary reference microphones.

Simulation results are shown in Fig. 5. Figure 5 shows the noise reduction in case the unwanted acoustic noise propagates from the noise source (Noise 1) in Fig. 3. Figure 5 (a) shows the results of the ANC systems using one of four microphones. It can be seen from Fig. 5 (a) that the ANC systems using Mic. 1 or Mic. 2 can reduce unwanted acoustic noise because these reference microphones satisfy the causality condition given by (9). Moreover, the ANC system using Mic. 2 has the highest noise reduction performance. This is because the Mic. 2 is the closest to the noise source (Noise 1). On the other hand, the ANC systems using Mic. 3 or Mic. 4 cannot reduce unwanted acoustic noise because these microphones does not satisfy the causality condition given by (9).

Figure 5 (b) shows the results of the ANC systems using two of four microphones. One of them is Mic. 2 that yields the best noise reduction performance in Fig. 5 (a). It can be seen from Fig. 5 (b) that the multi-channel ANC systems using two reference microphones have higher noise reduction performance than the single-channel ANC systems using one reference microphone. Moreover, the ANC system using Mic. 1 and Mic.2, which satisfy the causality condition (9), yields the highest noise reduction performance.

Figure 5 (c) shows the results of the ANC systems using three of four microphones or all the microphones. Two of them are Mic. 1 and Mic. 2 that yield the best noise reduction performance in Fig. 5 (b). It can be seen from Fig. 5 (c) that the multi-channel ANC systems using more than two reference microphones have lower noise reduction performance than the multi-channel ANC systems using Mic. 1 and Mic. 2. This is because Mic. 3 and Mic. 4, which do not satisfy the causality condition, affects the noise reduction performance. Moreover, it can be seen that convergence speed becomes slower with the number of reference microphones.

From these results, the ANC system using only reference microphones satisfying the causality condition can realize superior noise reduction performance.

4.2. Noise reduction performance in case where noise environment is changed

In this section, we demonstrate the noise reduction performance of the proposed ANC system in case where noise environment is changed. In the simulation, the unwanted acoustic noise is generated from the noise source “Noise 1” from 0 to 20 seconds and from 40 to 60 seconds, and from the noise source “Noise 2” from 20 to 40 seconds. The proposed ANC system estimates the arrival direction of noise using TDOA every 2 seconds. However, it is assumed that the delay of noise control part $D_c = 0$ in the simulations. The length of signals used to calculate TDOA is equal to the length of the noise control filter.

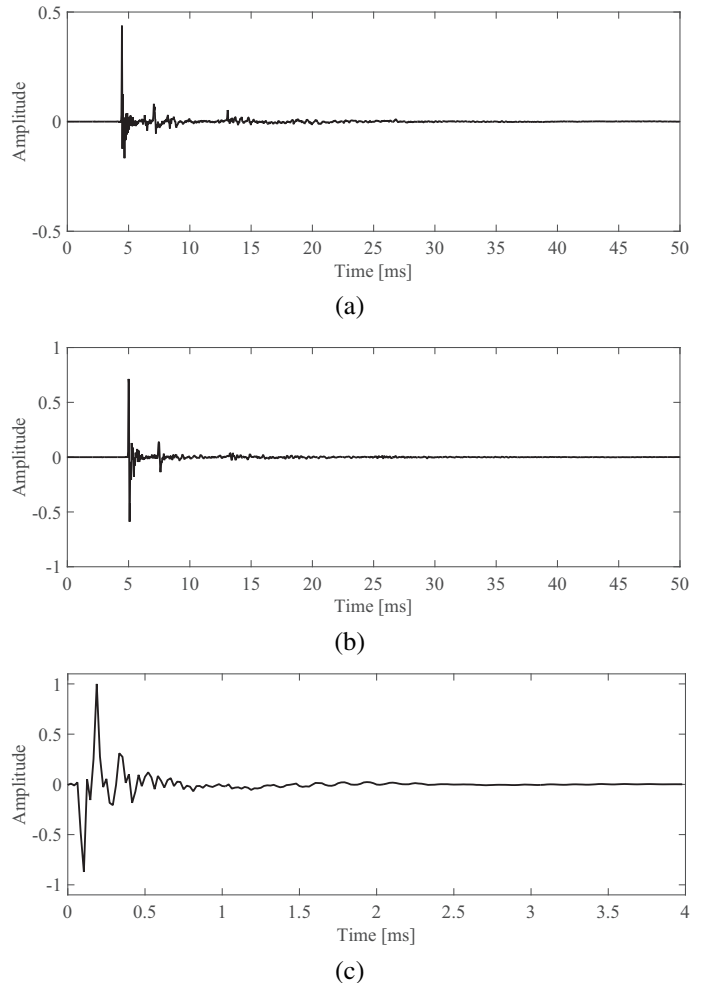

Fig. 4. Examples of impulse response of acoustic path. (a) reference path, (b) primary path, and (c) secondary path and secondary path model.

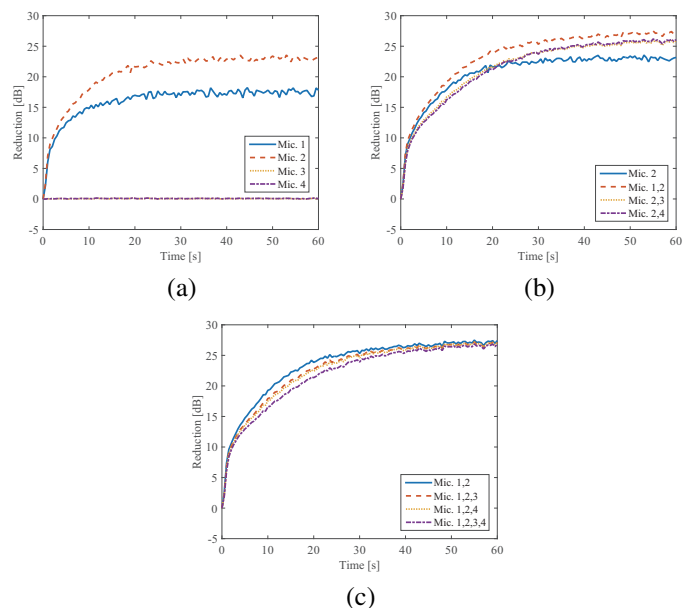

Fig. 5. Noise reduction performance where unwanted acoustic noise propagates from the noise source “Noise 1” in Fig. 3. (a) Using one reference microphone, (b) using two reference microphones, and (c) using three or four reference microphones.

Figure 6 shows the simulation results on the error signals picked up at the error microphone, the noise reduction performance, and selected reference microphones. From these results, the proposed ANC system can select the appropriate reference microphones to adapt the noise environment. However, the proposed ANC system cannot reduce the unwanted acoustic noise for several seconds after noise environment is changed. This is because the proposed ANC system uses the reference microphones that does not satisfy the causality condition during the calculation of TDOA. Moreover, the noise level slightly increases immediately after the change of noise environment because the “antinoise” is generated from the inappropriate reference signals. In addition, larger step-size parameter yields faster convergence speed.

5. CONCLUSION

In this paper, we proposed an ANC system that estimates the arrival direction of unwanted acoustic noise for optimizing the reference signals and demonstrated the effectiveness of the proposed ANC system through simulation results. The proposed ANC system can reduce unwanted acoustic noise by selecting the appropriate reference microphones in case where noise environment is changed.

In the future, we will examine the noise reduction performance when multiple unwanted acoustic noises simultaneously generate from various directions.

REFERENCES

- [1] P. A. Nelson and S. J. Elliott, *Active control of sound*, Academic Press, 1992.
- [2] S. J. Elliott and P. A. Nelson, “Active noise control,” *IEEE Sig. Process. Mag.*, vol. 10, no. 4, pp. 12–35, Oct. 1993.
- [3] S. M. Kuo and D. R. Morgan, *Active noise control systems*, John Wiley & Sons, 1996.
- [4] S. M. Kuo and D. R. Morgan, “Active noise control: a tutorial review,” *Proc. of the IEEE*, vol. 87, no. 6, pp. 943–973, Jun. 1999.
- [5] Y. Kajikawa, W. S. Gan and S. M. Kuo, “Recent advances on active noise control: open issues and innovative applications,” in *APSIPA Trans. Sig. Inf. Process.*, California, 2012, vol. 1.
- [6] H. Janocha and B. Liu, “Simulation approach and causality evaluation for an active noise control system,” *Proc. IEE Control Theory and Applications*, vol. 145, issue 4, pp. 423–426, Jul. 1998.
- [7] X. Kong and S. M. Kuo, “Study of causality constraint on feedforward active noise control systems,” *IEEE Trans. on Circuits and Systems*, vol. 46, no. 2, pp. 183–186, Feb. 1999.

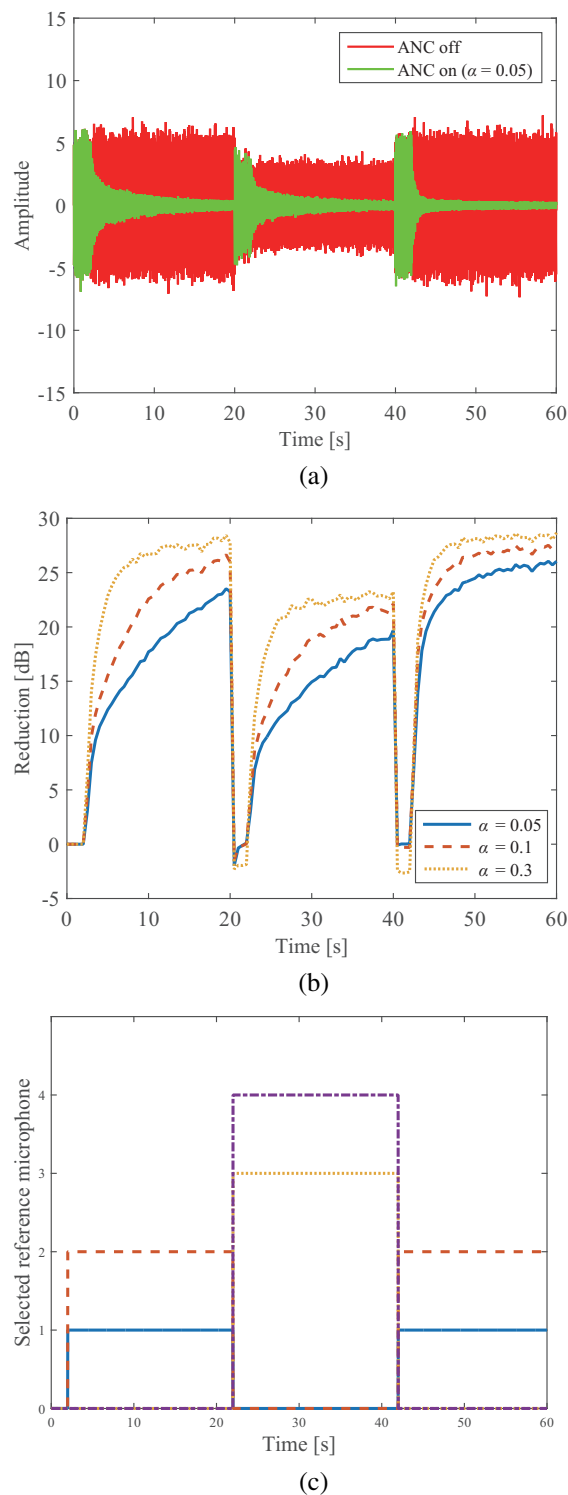

Fig. 6. Noise reduction performance in case where noise environment is changed. (a) Error signal, (b) reduction, and (c) selected reference microphones.