

# ADAPTIVE ARRAY BEAMFORMING FOR FREQUENCY HOPPING MODULATION

Montse Nájjar, Miguel A. Lagunas.

Department of Signal Theory and Communications, Universitat Politècnica de Catalunya  
c/. Gran Capità s/n, 08034 BARCELONA, SPAIN  
Phone:34-3-4017051. Fax: 34-3-4016447.

## ABSTRACT

A new architecture for Array Processing using Frequency Hopping (FH) modulation is addressed in this paper which takes advantage of the knowledge of the frequency sequence at the receiver, requiring neither temporal nor spatial a priori reference. Consequently, the paper deals with a Code Reference Beamformer (CRB). The proposed framework is composed of two parallel processors. The first one, the Anticipative processor, is devoted to predict the scenario at the hop frequency before this frequency is transmitted, providing a fast convergence of the second processor and avoiding the fall of the Signal to Interference plus Noise Ratio (SINR) with the frequency hops. The second one, the On-line processor, provides maximum SINR by applying the optimum beamvector which can be estimated minimizing the Mean Square Error (MSE) at the array output or, directly, maximizing the SINR.

## 1. INTRODUCTION

Frequency Hopping is a method of spectrum spreading widely used to make a communication system less vulnerable in front of interferences [1]. It consist of a system in which the carrier frequency is pseudorandomly hopped over a wide band,  $W_{ss}$ , under the control of a pseudonoise sequence. The signal bandwidth on each hop is much smaller than  $W_{ss}$ , however, the FH signal spectrum, averaged over many hops, occupies the entire spread spectrum bandwidth. Current technology permits FH bandwidths of the order of several GHz and rates greater than 1 Mhop/sec. The application of FH modulation in an antenna array will improve substantially the output SINR as a consequence of the increase of the interference rejection. Nevertheless, little information is available on performance of arrays with FH signals. Acar and Compton [2] studied the adverse effects of FH modulation in a time reference adaptive array based on the Least Mean Square (LMS) algorithm. They determined the FH modulation causes the LMS array to modulate both the amplitude and the phase of the received signal. Also it causes the array output SINR to vary with time and hence, increases the bit error probability for the demodulated signal. The reason is that the changes in the signal frequency due to the FH modulation are seen by the algorithm as changes in the signal direction of arrival, providing some discontinuities in the adaptive algorithm when used with FH modulated signals. Consequently, as the desired signal frequency jumps become larger, the jumps in the interelement phase shift at each hop augment. A larger jump means that the array weights are farther from their optimal values at the new frequency. Thus, a larger weight transient is required, more envelope and phase

modulation are produced and the SINR is lower after the hop. Bakhru and Torrieri [3] proposed a specific method for adaptive arrays using FH signals, the Maximin algorithm, which is based on the spectral characteristics of these signals, requiring neither a temporal reference signal nor a spatial one for its implementation. The algorithm, specially designed to operate against interference with a uniform spectrum, maximizes the SINR by maximizing the desired signal output power and simultaneously minimizing the interference plus noise output power. The same authors [4] suggested three different techniques of frequency compensation for the Maximin algorithm to avoid the algorithm discontinuities: Parameter-dependent processing uses an adaptive filter behind each antenna element being the most complicated to implement and the one which presents largest convergence, while the variability of the SINR decreases slightly; Spectral processing, based on a division of the total hopping band into a number of spectral regions, is the simplest to implement, but the achieved improvement is not significant; finally, the Anticipative processing which begins adaptation toward the optimum weights for a carrier frequency before this frequency is transmitted, provides the fastest convergence but exhibits the worst behavior. Lastly, Eken [5] proposed a modified sidelobe canceller to be used with FH signals which needs a priori knowledge of the direction of arrival of the desired signal.

This paper deals with an adaptive CRB which, taking advantage of the frequency sequence knowledge, avoids the fall of the SINR with the frequency hops. The proposed framework is composed of two parallel processors which yield the well-known optimum beamforming:

$$\mathbf{w}_{opt} = \mu \mathbf{R}_n^{-1} \mathbf{s}_d \quad (1)$$

Both processors, denoted as the Anticipative and the On-line processors, will be described in the sections 2 and 3, respectively; in the section 4 some simulation results will be shown; finally, the conclusions of this paper will be reported.

## 2. ANTICIPATIVE PROCESSOR

The Anticipative processor is considered for estimating the inverse of the covariance matrix due to the noise and interferences at fixed frequencies that are going to be present or active at the next frequency hop. Thus, in the Anticipative processor the received signal is dehopped with a carrier frequency before its transmission,  $f_{i+1}$  (Figure 1). The resultant snapshot  $\mathbf{x}_{ant}(t)$  contains the noise and interferences that will appear in the next hop, while the desired signal at the hop frequency  $f_i$  is rejected by the dehopping with  $f_{i+1}$ . Hence, the required inverse covariance matrix  $\mathbf{R}_n^{-1}$ , is calculated beforehand from the snapshots acquired during the whole hop

---

This work was supported by the National Research Plan of Spain, CICYT, Grant number TIC95-1022-C05-1.

time at the anticipative dehoppping output, allowing a fast SINR maximization when the hop occurs and avoiding the SINR variations of the previous FH systems.

### 3. ON-LINE PROCESSOR

In the On-line processor, the signal received at each array sensor is mixed with a local oscillator which hops synchronously with the received signal and then passes through a narrowband filter with the purpose of dehop the desired signal. Therefore, the dehoppping precedes the beamforming, allowing bandwidth reduction and canceling the noise and interferences outside the signal band before they can enter the adaptive filters. After the on-line dehoppping, the SINR should be maximized minimizing the noise and suppressing any directional interference impinging in the array. Consequently, the optimum beamvector (1) has to be applied, which, thanks to the Anticipative processor, can be implemented in two stages (Figure 1).

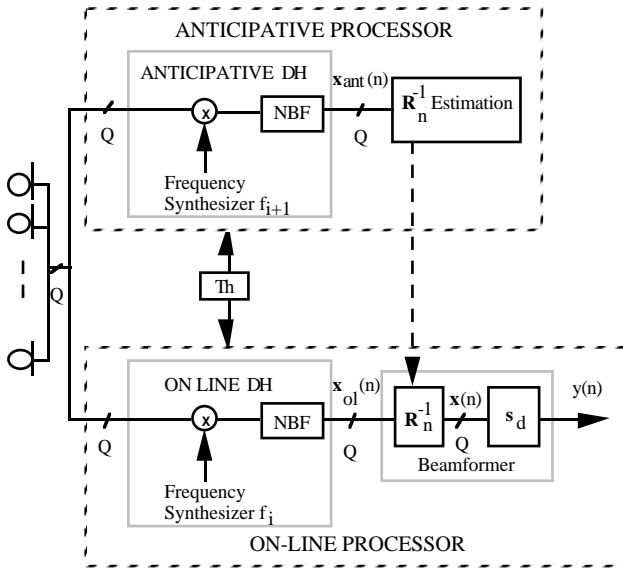

Figure 1. Two Stage Code Reference Beamformer for FH

The first stage consist on the product of the dehopped signal  $\mathbf{x}_{ol}(t)$  by the inverse of the interferences plus noise covariance matrix  $\mathbf{R}_n^{-1}$ , estimated in the Anticipative stage and transferred to this stage when the hop occurs. This preprocessing, assuming strong interferences in comparison with sensor noise, cancels the interference signals by orthogonal projection [6].

The second stage is devoted to focus the desired signal by multiplying the output of the first stage  $\mathbf{x}(t)$  by the steering vector of the desired signal  $\mathbf{s}_d$ . The a priori knowledge of this beamvector would require: on the one hand, the a priori knowledge of the direction of arrival of the desired signal, not disposal at some applications as, for instance, mobile communications systems; on the other hand a proper calibration of the array. However, these assumptions are not necessary in the proposed CRB thanks to the Anticipative processor. The prediction of the scenario available at the Anticipative processor allows the implementation of the first stage of the beamformer. From the preprocessed signal  $\mathbf{x}(t)$  and, without a priori information neither about the received signal nor about the array, it is possible to estimate, simultaneously to the reception of the signal, the second stage of the beamforming in an adaptive way. This estimation can be

done minimizing the MSE or, directly, maximizing the SINR. In both cases, the estimated beamvector yields the desired steering vector  $\mathbf{s}_d$  resulting the complete processing equal to the optimum beamforming (1).

#### 3.1 Maximum Signal to Interference plus Noise Ratio (MSINR)

The maximization of the SINR derives in a problem of generalized eigenvalue decomposition of the pencil  $(\mathbf{R}_x, \mathbf{R}_n^{-1})$ , where  $\mathbf{R}_x$  is the covariance matrix of the signal at the output of the first stage  $\mathbf{x}(t)$ . From this decomposition, it results that the generalized eigenvector associated to the maximum generalized eigenvalue is equal to the steering vector  $\mathbf{s}_d$ , whenever the interfering signals present in the scenario are fixed frequency interferences. Thus, they are present in the scenario predicted by the Anticipative stage and suppressed automatically by the  $\mathbf{R}_n^{-1}$  preprocessing. However, if new interferences appear during the hop time at the frequency hop, they will not be canceled by the inverse of the noise covariance matrix estimated in the previous hop. In this case the system has to be able to change its pattern in response to the new signal environment, optimizing the SINR at the array output. Therefore, the On-line processor has to be completed. Once the generalized eigenvector estimation has converged to the steering vector for a given hop frequency, the array gain in this pointing direction can be constrained to the unity. Then, the output power signal is minimized suppressing any directional component impinging in the array from angles of arrival different of the desired look direction. This is a problem of constrained minimization power whose solution can be implemented by the so-called Generalized Sidelobe Canceller (GSLC), originally proposed by Griffiths and Jim [7], which consists of two different paths. In [8], an adaptive approach for estimating the complete beamformer, resulting from the maximization of the SINR, has been proposed and evaluated.

#### 3.2 Minimum Mean Square Error (MMSE)

The minimization of the MSE between the array output and a reference signal correlated with the desired signal, with correlation equal to  $\rho$ , and uncorrelated with the noise, yields the desired steering vector modified by a scalar:

$$\mathbf{w}_{opt} = \rho \frac{1}{\text{SINR}_d} \mathbf{s}_d \quad (2)$$

where  $\text{SINR}_d = \alpha_d^2 \mathbf{s}_d^H \mathbf{R}_n^{-1} \mathbf{s}_d$  is the Signal to Interference plus Noise Ratio in the desired look direction.

Thanks to the first stage of the proposed CRB, the required reference signal can be easily regenerated from the received snapshot  $\mathbf{x}(n)$ . Since the preprocessing by  $\mathbf{R}_n^{-1}$  is equivalent to an orthogonal projection to the interference space, the snapshot  $\mathbf{x}(n)$  only contains the desired signal with noise. Hence, a demodulation of this noisy signal followed by a remodulation, allows to get the required reference signal. Still another possibility is the envelope control of the received signal for constant amplitude modulation. Because the transmitted signal in FH systems is usually a MSK modulated signal, a feasible alternative is to use the envelope error as an error signal to drive the MMSE algorithm, applying the Constant Modulus Algorithm (CMA) [9]. This algorithm allows the cancellation even of follower jammers that may appear during the hop time.

#### 3.3. Processing Shortcuts

Taking advantage of the knowledge of the frequency

sequence, the convergence of the algorithm to the steering vector can be accelerated by frequency focusing. Once the CMA or the generalized eigenvector estimation algorithm has converged to the steering vector for a given hop frequency  $s_{di}$ , the steering vectors for the rest of the sequence frequencies will be immediately obtained assuming fixed the angle of arrival of the desired source and the array properly calibrated. Since the frequency dependence of the steering vectors is on the phases of its components and this dependence is linear, a slight modification of  $s_{di}$ , consisting in a phase multiplication by the frequency ratio  $f_j/f_i$ , provides the steering vector for the  $j$ -th hop. Nevertheless, dealing with mobile communication systems or arrays having sensors displacement or phase perturbations, continuous adaptation is convenient to allow to track the nonstationary effects. Nonetheless, the focusing of the steering vector at the end of each hop  $s_{di-1}$ , to the new one  $s_{di}$ , avoids to have an acquisition time when each hop occurs. Afterward, the algorithm will continue the adaptation from this new steering  $s_{di}$ . Moreover, most of the nonstationary effects produce slow changes in the steering vector compared with the hop frequency. For instance, the variations due to the phase and quadrature missadjustment in the down conversion chain which occur depending on the thermal changes.

#### 4. SIMULATION RESULTS

The presented simulations have been made with a linear equally spaced array of 4 sensors, in which the interelement separation was half wavelength at the center frequency of the hopping band. The desired source, located at 20 degrees from the broadside direction, was a MSK signal (1 sample/symbol, assuming accurate timing) centered at 900 MHz, with 5 dB of  $E_b N_0$  ( $BER = 10^{-1}$ ). This signal has been spread uniformly over a relative bandwidth equal to the 50 per cent, which is the ratio of the total hopping bandwidth to the center frequency. The dwell time or duration of the hop interval was set equal to the duration of 250 symbols. Therefore, Slow FH modulation is considered. A random sequence of 1000 symbols was collected and analyzed, so, 4 frequency hops occurred. A multitone jamming was present in the scenario from a direction of arrival of -30 degrees. This interference was distributed over the spread-spectrum bandwidth, consisting of tones over half the frequency channels, the even hops. The interference to noise ratio in each channel was 20 dB. The simulations have been focused in the evaluation of the CRB obtained minimizing the MSE.

First of all we evaluate the improvement achieved by the two stage receiver in front of a classical Time Reference Beamformer (TRB) of one stage, without the Anticipative processor. Obviously, if the preprocessing by  $\mathbf{R}_n^{-1}$  is not considered, the second stage needs a priori knowledge of a time reference correlated with the desired signal. In Figure 2, the evolution of the output SINR obtained without including the Anticipative processor is represented, where the optimum SINR appears in dashdot line. It can be observed the decay of the SINR when each hop occurs. However, the fluctuation of the SINR at the output of the two-stage system applying the CMA, Figure 3, is negligible, being the BER obtained equal to  $10^{-3}$ . It is important to remark that, thanks to the first stage, the required reference signal has been regenerated from the data without previous knowledge. In Figure 4, the evolution of the beamvector shows the effect of the frequency focusing, which avoids the acquisition time at each frequency hop.

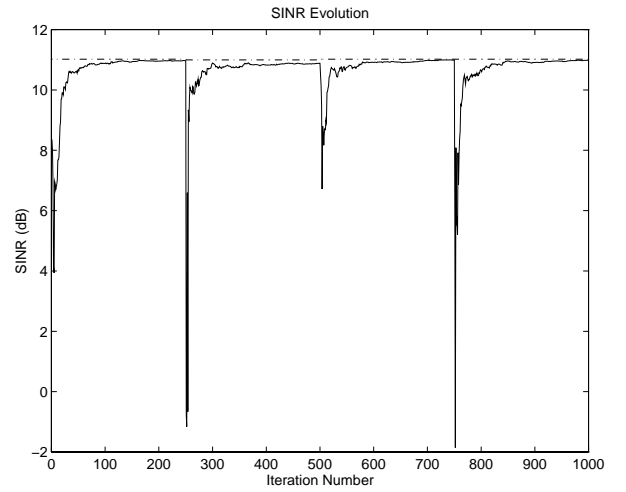

Figure 2. SINR evolution of the TRB assuming exact knowledge of the reference: solid line. Optimum SINR: dashdot line.

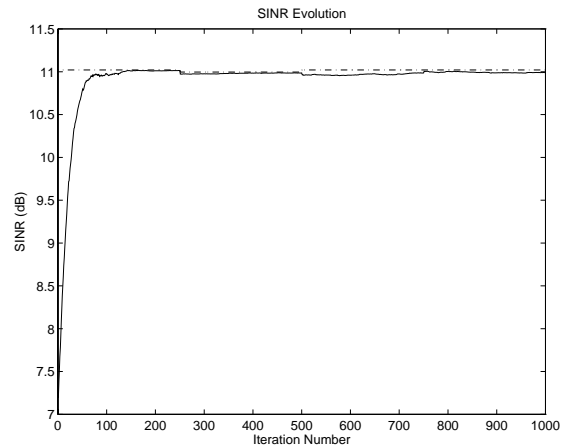

Figure 3. SINR evolution of the two-stage CRB applying the CMA: solid line. Optimum SINR: dashdot line.

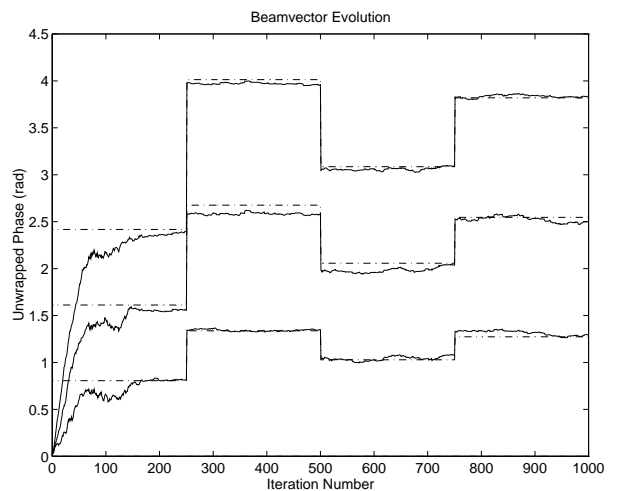

Figure 4. Evolution of the adaptive coefficients of the two-stage CRB array : solid line. Optimum beamvector : dashdot line

In a second simulation, a follower jammer, radiating from 60 degrees, was added to the scenario. This interference hopped with the same sequence as the desired signal with a delay of half the hop duration (125 symbols). The interference to noise ratio was 20 dB. In Figure 5, it can be seen the fluctuation of the SINR output when the follower jammer appears which shows the fast convergence of the CMA canceling this new interference. The array factors got at each hop frequency are represented in Figure 6, the optimum beamformers with dashdot line and the adapted ones with solid line. These diagrams show the nulls at the direction of arrival of the interferences: the follower jammer (60 degrees) and the fixed frequency interference (-30 degrees) at the even hops.

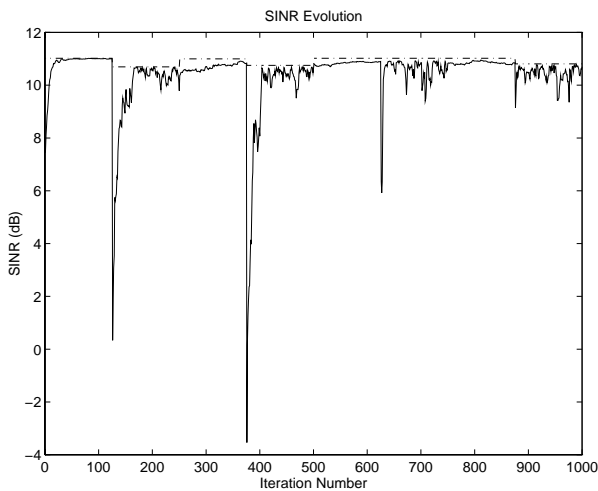

Figure 5. SINR evolution of the two-stage CRB applying the CMA when a follower jammer radiating from 60 degrees (INR=20 dB) appears in the scenario: solid line. Optimum SINR: dashdot line.

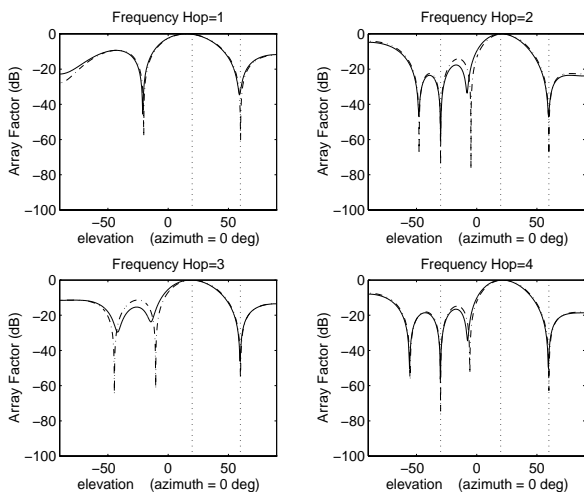

Figure 6. Radiation patterns of the two-stage CRB with the desired source located at 20 degrees ( $E_b/N_0 = 5$  dB), with a multitone interference radiating in the even hops from -30 degrees (INR=20 dB) and a follower jammer from 60 degrees (INR=20 dB): solid line. Optimum radiation patterns: dashdot line.

## CONCLUSIONS

A new adaptive receiver for Frequency Hopping modulated signals in Array Processing has been reported in this paper. The application of FH modulation in an antenna array improves the interference rejection and allows the implementation of a beamformer based on a code reference (CRB), the frequency sequence, which provides continuous self-calibration of the array. The proposed framework is composed of two different processors: The first one, the Anticipative processor, is considered for estimating the inverse of the covariance matrix due to the noise and interferences at fixed frequencies that are going to be present or active at the next frequency hop; The second one, the On-line processor is devoted to maximize the output Signal to Interference plus Noise Ratio (SINR) suppressing also follower jammers that might appear during the hop time.

## REFERENCES

- [1] Simon M. , Omura J. , Scholtz R. , Levit B. , "Spread Spectrum Communications", Computer Science Press, 1985.
- [2] Acar L. ,Compton R. , "The Performance of an LMS Adaptive Array with Frequency Hopped Signals", IEEE Transactions on Aerospace and Electronic Systems, vol. AES-21, no. 3, pp. 360-371, May 1985.
- [3] Bakhr K. , Torrieri D. , " The Maximin Algorithm for Adaptive Arrays and Frequency-Hopping Communications", IEEE Transactions on Antennas and Propagation, vol. AP-32, no. 9, pp. 919-928, September 1984.
- [4] Torrieri D. , Bakhr K. , "Frequency Compensation in an Adaptive Antenna System for Frequency-Hopping Communications", IEEE Transactions on Aerospace and Electronic Systems, vol. AES-23, no. 4, pp. 448-467, July 1987.
- [5] Eken F. , "Use of Antenna Nulling with Frequency Hopping Against the Follower Jammer", IEEE Transactions on Antennas and Propagation, vol. AP-39, no. 9, pp. 1391-1397, September 1991.
- [6] Hudson J. E. , "Adaptive Array Principles", IEE Electromagnetic Series 11, London and New York, 1981.
- [7] Griffiths L. , Jim C. , "An Alternative to Linearly Constrained Adaptive Beamforming", IEEE Transactions on Antennas and Propagation, vol. AP-30, no. 1, pp 27-34, January 1982.
- [8] Nájár M. , Lagunas M. A. , "High Resolution Adaptive Arrays Based on Random Processing Techniques: Frequency Hopping Modulation", ICASSP-95, vol. 3, pp. 1737-1740, Detroit (USA), May 9-12, 1995.
- [9] Gooch R. , Lundell J. , " The CM Array: An Adaptive Beamformer for Constant Modulus Signals", ICASSP-86, Tokio, April 1986.